



152 Robbins Rd, Downingtown, PA, 19335, USA - HuddleCamHD.com | 1 800 - 486-5276

HuddleCamHD Serial Joystick Controller

Model Number: HC-JOY-G2

Joystick Keyboard Installation & Operation Manual

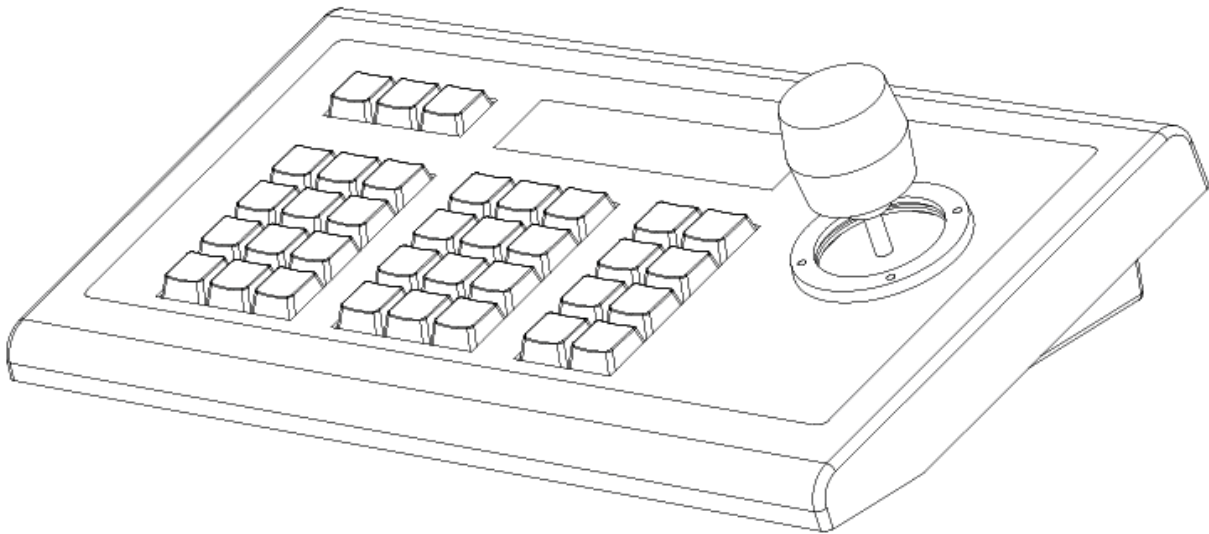

Easy pan, tilt & zoom controls for any RS-232, RS485, RS422 VISCA, Pelco-P or Pelco-D protocol camera!

Controls pan & tilt with variable speed.

Uses 3 dimensional joystick with “twist” control for variable zoom.



152 Robbins Rd, Downingtown, PA, 19335, USA - HuddleCamHD.com | 1 800 - 486-5276

Key Product Features

- All Metal housing.
- VISCA, PELCO-D and PELCO-P protocol support.
- Large LCD Menu display.
- Key-press “BEEP” confirmation (optional - set on or off).
- Pan, tilt, zoom, iris and focus control.
- Variable speed control of pan, tilt and zoom.
- Auto/Manual Focus and Iris.
- Backlight Compensation control.
- Cameras #1-4 ‘Quick Key’ Select buttons.
- Preset Save, Call and Clear.
- Real time display of the current status.
- Short circuit and overcurrent protection.
- Automatic recovery program for the communication port(s).

Key Technical Specifications

- Control Interfaces:
RS232 full-duplex, RS485 semi duplex, RS422 full-duplex.
- Variable Baud Rate 1200 to 19200 bps.
- Maximum communication distance: RS485: 3,937ft [1200m] using 24 gauge twisted pair cabling
- Can control a maximum 255 cameras.
- Voltage: 12VDC.
- Power Consumption: 6W Max.
- Display: LCD.
- Working Temperature: 14°F ~ 122°F [-10° ~ +50° C].
- Working Humidity: 10 ~ 90% (non-condensation).
- Weight 3.4 lbs. [1.6 kg]
- Dimensions: 12.6”(W) x 7.1”(D) x 4.3”(H) [320mm x 181mm x 110mm].



152 Robbins Rd, Downingtown, PA, 19335, USA - HuddleCamHD.com | 1 800 - 486-5276

In the Box

- Keyboard with three-axis control joystick.
- 5p screw terminal plug (RS422/RS485).
- 12VDC Power Supply.
- This Manual.

Installation

- Power Supply Interface (5.5mm x 12mm center pin JEITA style jack): 12VDC / 2000mA power supply.
- RS485/422 interface (5p screw terminal): 1:485+/422TxA, 2:485-/422TxB, 3:422RxA, 4:422RxB, 5:485/422Gnd.
- RS232 interface (DB9M port): 2:Rx, 3:Tx, 5:Gnd.

Hardware Features

- Keys: momentary push buttons (keys).
- Joystick: 3-axis joystick.
- Digital display: LCD display.

Control Mode

- VISCA, PELCO-P and PELCO-D protocol support.
- Control interfaces:
 - 5p Screw Terminal (RS485/RS422).
 - DB9 (RS232).
- Baud rate: 1200, 2400, 4800, 9600, 19200.
- Parameters: 8 bits, 1 stop bit, No parity.



152 Robbins Rd, Downingtown, PA, 19335, USA - HuddleCamHD.com | 1 800 - 486-5276

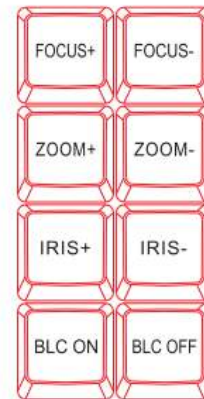
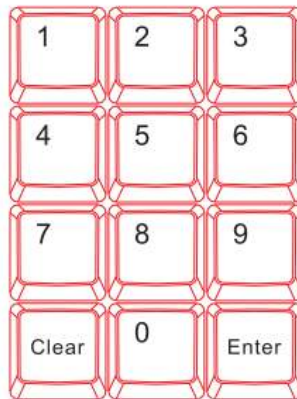

Keyboard/Joystick Operation

Basic Control

- **Pan & Tilt Control**
 - Joystick movement provides variable speed pan and tilt of the camera head.
- **Zoom Control**
 - Rotation of the joystick controls variable speed zoom of the lens.
 - Clockwise rotation of the joystick = zoom in.
 - Counter-clockwise rotation of the joystick = zoom out.
 - Incremental Zoom control can also be achieved using the following keys: “Zoom+”, “Zoom-”.

Manual Control Options

- **Focus Control** - (VISCA Only, Pelco-P & D do not provide for “Man Foc”)
 - Incremental Focus control can also be achieved using the following keys: “Focus+”, “Focus-” (“Man Foc” must first be enabled).
 - Auto Focus may be enabled by pressing the “Aut Foc” key.
 - Manual Focus may be enabled by pressing the “Man Foc” key.
- **Iris Control** - (VISCA Only, Pelco-P & D do not provide for “Man Exp”)
 - Incremental Iris control can also be achieved using the following



152 Robbins Rd, Downingtown, PA, 19335, USA - HuddleCamHD.com | 1 800 - 486-5276

- keys: “Iris+”, “Iris-” (“Man Exp” must first be enabled).
- Auto Iris may be enabled by pressing the “Aut Exp” key.
- Manual Iris may be enabled by pressing the “Man Exp” key. Note: Some cameras do not have an “Iris” (or manual Iris) mode. For this reason, Manual Exposure is used. Therefore, for best results, use the camera’s IR remote to first select a desired shutter speed before using “Man Exp”, “Iris+ ”and “Iris-“
- **Backlight Compensation Control - (VISCA Only, Pelco-P &-D do not provide for BLC)**
 - Backlight Compensation may be enabled by pressing the “BLC On” key. Use this setting for shooting backlit subjects.
 - Backlight Compensation may be disabled by pressing the “BLC Off” key. Use this setting for shooting subjects with balanced, 3 point, overhead or front lighting.

Selecting a Camera

- **Input Number Keys**
 - For entering numbers use the “0” through “9” keys.
 - Press “Enter” key to complete commands.
 - Press the “Clear” key to clear entries before confirming with “Enter” key.
- **Set the Camera ID to be controlled by joystick**
 - Press “Addr” key, desired “Number” key and then “Enter” key.
 - Alternatively you can use the “Cam 1” through “Cam 4” quick-select buttons to quickly access cameras 1-4.

PTZ Presets

- **Set a PTZ Preset**
 - Use joystick and keyboard to set up the desired preset shot. Press the “Set” key, press a “Number” key and then the “Enter” key. To leave “Set” mode, press the “Esc” key.
- **Call a PTZ Preset**
 - Press the “Call” key, press a “Number” key and then the “Enter” key.
 - You may leave the unit in “Call” mode and continue to enter sequential preset calls. To leave “Call” mode, press the “Esc” key.
- **Clear a PTZ Preset**
 - Press “Esc” key to return to main menu. Press the “Clear” key,



152 Robbins Rd, Downingtown, PA, 19335, USA - HuddleCamHD.com | 1 800 - 486-5276

press a “Number” key and then the “Enter” key. To leave “Clear” mode, press the “Esc” key.

- **Send camera to its “Home” PTZ Position**
 - Press the “Home” key. Note: When in Pelco-P or -D, this button will call preset 0, instead of Home. Pelco-P and -D do not provide for a “Home” position. You must first set preset 0 to use this feature with Pelco)

Notes on using presets with VISCA:

For your convenience, the HC-JOY-G2 uses the same preset numbers whether ‘set’, ‘called’ or ‘cleared’ via hand-held IR remote, VISCA, Pelco-P or Pelco-D. This is in contrast to Sony’s traditional offset of -1 between IR remote commands and VISCA commands. If you are used to Sony’s traditional method, you no longer need to make this adjustment.

Keyboard/Joystick Configuration - LCD Menu

- **Go to Main Menu or Backup up one Menu Level**
 - Press “Esc” key to return to main menu. Note: Repeated presses may be required depending on how deep you are in a menu.
- **Obtain Product Information**
 - Press the “Info” key.
 - Use Joystick “Up” and “Down” to scroll through info (Model, Serial Number, Keyboard ID, Key Sound setting).
- **Configure Keyboard/Joystick**
 - Press and Hold the “Setup” key for 3 seconds.
 - Enter the password. “8888” is the default password.
 - Press the “Enter” key.
- **Keyboard Menu**
 - “Set >>” Menu
 - Move joystick “left” and “right” to select between 1(CAM) or 2(SYS)
 - Press “Enter” key to confirm the choice.
 - “SET >>CAM” : Menu
 - Move Joystick “left” and “right” or simply type camera ID to select camera to configure.
 - Press “Enter” key to confirm the choice.
 - Move Joystick “up” and “down” to choose between setting either the control protocol or baud rate settings.



152 Robbins Rd, Downingtown, PA, 19335, USA - HuddleCamHD.com | 1 800 - 486-5276

- Move Joystick “left” and “right” to select the desired control protocol or baud rate (to match that of camera).
- Repeat for all camera IDs required.
- Press “Esc” to return to previous menu level.
- “SET >>SYS” : Menu
 - Move Joystick “left” and “right” to select system parameter to configure.
 - Press “Enter” key to confirm the choice.
 - 1(EDIT PW)
 - OLD PW: Using “Number” keys, enter the current password (default = “8888”). Press “Enter” key to confirm.
 - NEW PW: Using “Number” keys, enter the desired password (4 numeric keys) Press “Enter” key to confirm.
 - AGAIN PW: Using “Number” keys, re-enter the desired password (4 numeric keys) Press “Enter” key to confirm.
 - 2(FACTORY)
 - SURE?: Press “Enter” key to confirm.
 - 3(LOAD ISP)
 - Press “Enter” key to confirm.
 - SURE?: Press “Enter” key to confirm.
 - 4(SOUND)
 - Move Joystick “left” and “right” to turn key beep ON or OFF.
 - Press “Enter” key to confirm.
 - 5(KB ID)
 - KB ID: Using “Number” keys, enter the desired ID. Press “Enter” key to confirm.
 - 6(LOCK SET)
 - Move Joystick “left” and “right” to turn KB lock ON or OFF. Press “Enter” key to confirm.
 - LOCK PW: Using “Number” keys, enter the desired password (4 numeric keys). Press “Enter” key to confirm.
 - To unlock Keyboard/Joystick
 - Press “Esc” key until LCD shows “LOCKED”
 - LOCK PW: Using “Number” keys, enter the desired password (4 numeric keys). Press

- “Enter” key to confirm.
- LCD screen will go Black. Press “Enter” key again.
- OPEN LOCK: Using “Number” keys, enter the desired password (4 numeric keys). Press “Enter” key to confirm.

Keyboard/Joystick Connection Wiring and Indicators

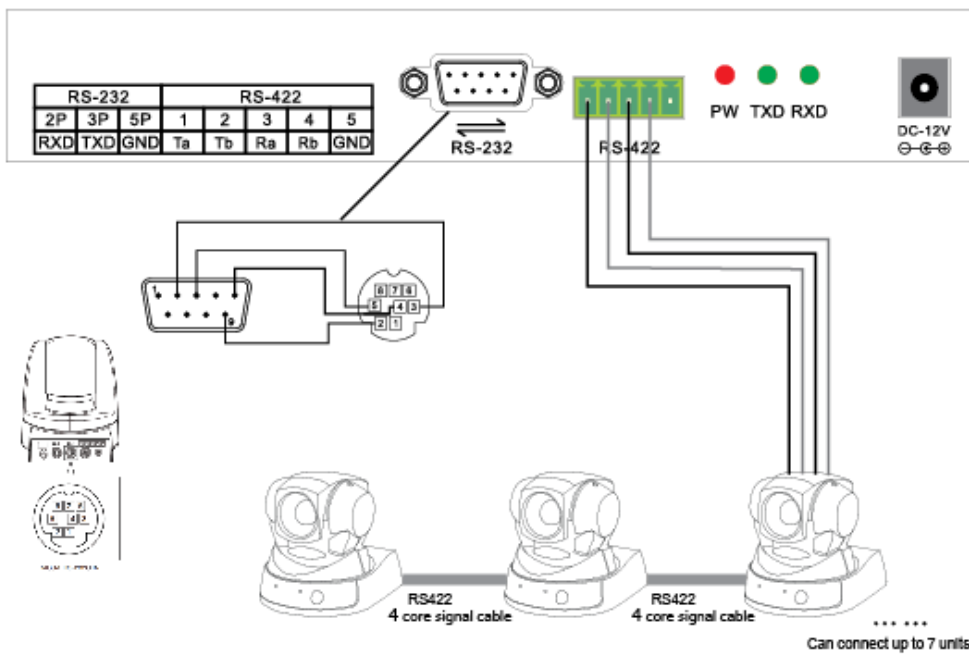

Indicators:

- “PW” illuminates Red when unit is powered
- “TXD” flashes green when unit is transmitting commands
- “RXD” flashes green when unit is receiving responses

Power:

- Keyboard/Joystick requires external 12VDC. Use only the 12VDC power supply shipped with the unit.

The Keyboard/Joystick may be connected to cameras via RS232, RS485 or RS422.



152 Robbins Rd, Downingtown, PA, 19335, USA - HuddleCamHD.com | 1 800 - 486-5276

- For RS232, connect the DB9 port of the KB to the miniDin8 (VISCA) port of the camera with pin-out as follows:
 - KB Tx - Pin 3----- Camera Rx - Pin 5
 - KB Rx - Pin 2----- Camera Tx - Pin 3
 - KB Gnd - Pin 5----- Camera Gnd - Pin 4

- For RS485, connect the 5p screw terminal port of the KB to the RS485 port of the camera with pin-out as follows:
 - KB Ta - Pin 1----- Camera (+)
 - KB Tb - Pin 2----- Camera (-)
 - KB Gnd - Pin 5----- Camera (G) (if present - some cameras will not require a G)

- For RS422, connect the 5p screw terminal port of the KB to the RS422 port of the camera with pin-out as follows:
 - KB Ta - Pin 1----- Camera (Rx-)
 - KB Tb - Pin 2----- Camera (Rx+)
 - KB Ra - Pin 3----- Camera (Tx-)
 - KB Rb - Pin 4----- Camera (Tx+)
 - KB Gnd - Pin 5----- Camera (G) (if present - some cameras will not require a G)

• Troubleshooting

- Cannot Control Camera at all
 - Check that LCD is in the Main Menu. Press “Esc” key to return to main menu, if needed. Note: Repeated presses may be required depending on how deep you are in a menu, e.g. this can often happen after setting presets and then attempting to Call presets without exiting the Set menu.
 - Check that PW Indicator is solid Red. If not, check power supply connection to KB and AC Mains. If still unlit, power supply or KB may be damaged.
 - Check both KB settings and Camera settings to ensure that the following ALL match:
 - Camera ID (e.g. 01, 02, etc...)



152 Robbins Rd, Downingtown, PA, 19335, USA - HuddleCamHD.com | 1 800 - 486-5276

- Camera Protocol (e.g. VISCA, PELCO-P, PELCO-D)
- Baud Rate (e.g. 9600)
- Check all KB-Camera connections and cabling per “Connection Wiring and Indicators” section above.
- Check TXD Indicator for Green flickering when cam is moved using the joystick. If not flickering, KB or its joystick may be damaged.
- Controlling more than 1 camera at a time.
 - Check all cameras to ensure that each has a unique ID.
 - Check all camera settings in KB menu to make sure that the protocol setting for that camera ID matches that of the actual camera.
 - Note, you cannot typically mix VISCA, Pelco-P or Pelco-D cameras in the same daisy chain.
 - Check control wiring.
 - For RS232, cabling must flow from KB into the VISCA-in port of the first camera and then from VISCA-out port of first camera to VISCA-in port of next camera, etc... With daisy chained RS232, no terminator is required on the last camera. A VISCA cross-over cable must be used for all camera to camera connections. These are available from HuddleCamHD in various lengths as well as from other sources.
 - For RS485 and RS422, all connections are in parallel (e.g. all cams' 485+ are connected to KB's 485+ and all cams' 485- are connected to KB's 485-) and termination may be required depending upon overall cabling distances involved.